

# LASER WELDERS & ACCESSORIES

WELD BEYOND LIMITS

# HTS Mobile Laser Welding System

The HTS laser welder is a device created with the processing of small series and individual details in mind, such as tools and molds of any dimensions and weight. HTS successfully finds application in various areas, including mold and tool construction, the electronics industry, the medical industry, and the aviation industry.



## WHY CHOOSE HTS MOBILE?

- Mobility and precision: HTS Mobile is a mobile arm-swivel design with a range of 0.9m-1.5m, eliminating vibrations, which guarantees precise processing. Thanks to the combination of a swivel arm, movable resonator, and an optional head with 360° rotary optics, HTS Mobile can work with almost any element, regardless of its size, geometry, or position.
- Design: The open construction of HTS Mobile allows for operation without the need for manipulating the workpiece, and the control of the mobile stand streamlines the welding process. Additionally, the swivel arm design enables practical positioning of the laser head, increasing work efficiency.
- Versatility: HTS finds its application in working with all available materials on the market, such as steel, bronze, precious metals, nitride steel and other difficult-to-machine materials.
- Intuitiveness: The HTS Mobile device is distinguished by its ease of movement and stable positioning, which is ensured by a digital-analog joystick with a Teach-In (learning) function. The minimal setup times achieved thanks to this advanced technology translate into work efficiency.

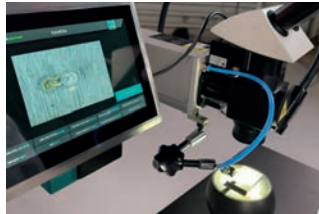
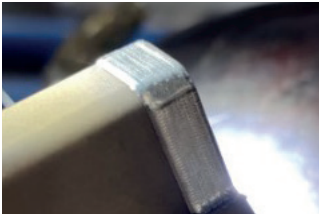

## LINEAR SYSTEM

- X / Y / Z axes motorized, driven by stepper motors, controlled by joystick
- Positioning speeds for digital and analog mode:
  - Maximum feed speed for X and Y Axes: 8.9 mm/s | 8.9 mm/s
  - Minimum feed speed for X and Y Axes: 0.19 mm/s | 0.16 mm/s
  - Maximum feed speed for Z Axis: 10 mm/s | 10 mm/s
  - Minimum feed speed for Z Axis: 0.25 mm/s | 0.25 mm/s
- Maximum feed distance:
  - Y axis 760 mm
  - X axis 480 m
  - Z axis 810 mm

## LASER OPTICS COMPONENTS

- 10x binoculars (Leica)
- Welding spot diameter regulator
- Directional mirror
- Focusing lens
- Protective glass
- LCD protective shutter

## DIMENSIONS AND WEIGHT

- Dimensions: width 950mm x height 1550mm x length 1250mm
- Weight: 370 kg net

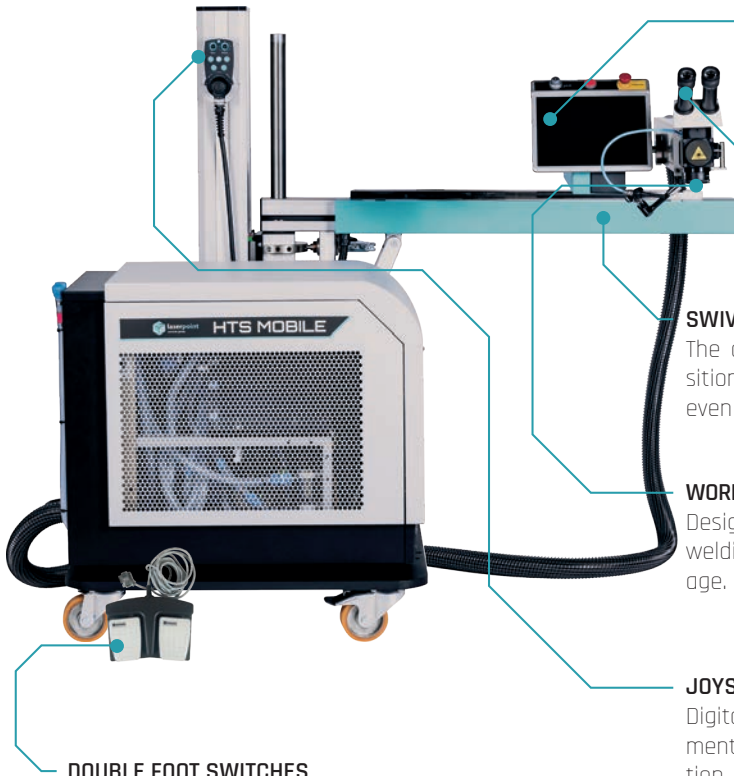

#### CONTROL PANEL

Clear 10" screen interface designed for user-friendly operation.

#### LEICA BINOCULARS

High-quality binoculars with 10x or 16x magnification for precise welding position determination with accuracy up to 0,01mm.

#### SWIVEL ARM

The arm design allows for practical positioning of the laser head and reaching even the most difficult-to-access places.

#### WORKING LENS WITH PROTECTIVE GLASS

Designed to protect delicate optics from welding splatter and mechanical damage.

#### JOYSTICK

Digital-analog joystick for smooth movement control in three axes + rotary motion, includes Teach-In function, synchronization relative to feed (0,05 - 3 mm) and intuitive welding path programming.

#### DOUBLE FOOT SWITCHES

Enables two welding modes (single or continuous) with automatic shielding gas supply function.

#### TECHNOLOGY AND EQUIPMENT OF HTS MOBILE:

- Laser resonator with ball mounting
- Laser source utilizing Nd: YAG Crystal
- Interface with system control and monitoring function
- Control panel for adjusting machine operation, including power parameters, pulse time, and frequency
- Efficient, internal water-air cooling system with the option to connect an additional external cooling system
- Protective gas supply controlled by a magnetic solenoid valve

#### TECHNICAL PARAMETERS

	HTS 160	HTS 200	HTS 300
Laser type	Nd: YAG	Nd: YAG	Nd: YAG
Max. mean power	160W	200W	300W
Pulse peak power	9 kW	11 kW	13 kW
Max. pulse energy	100 J	120 J	150 J
Pulse duration	0,2 - 20 ms		
Pulse frequency	0,5 - 20 Hz		
Focus diameter	0,05 - 2,0 mm		
Line voltage (V/Ph/Hz)	380 - 420 V AC / 3 Phase		
<b>No.</b>	<b>HTS-LP160</b>	<b>HTS-LP200</b>	<b>HTS-LP300</b>

# ECO Laser Welder

The ECO laser welder is a device created with small series processing and individual details in mind, like tools and molds, weighing up to 120 kg. ECO versatility makes it suitable for various industries including automotive, electronics, medical, jewelry, machine construction, molds and tools, and aerospace.



## WHY CHOOSE ECO?

- Precision: The ECO Laser Welder ensures excellent quality of welding processes even for smallest details.
- Construction: ECO is ergonomically designed for efficient operator's work. Its open construction allows easy manipulation of the processed element, while the worktable control function streamlines the welding process.
- Versatility: ECO can work with all available materials on the market, such as steel, bronze, precious metals, nitride steel, and other difficult-to-machine materials.
- Flexibility: Its compact dimensions and mobility enable installation in small workspaces.
- Intuitiveness: The technology used in ECO, an intuitively controlled joystick, and a 10" touch screen ensures exceptionally efficient and comfortable operation.

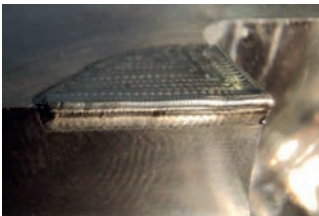

## LINEAR SYSTEM

- Motorized X / Y axes driven by stepper motors, Z axis with a brush motor, controlled by joystick
- Variable positioning speeds for digital and analog mode:
  - Maximum feed speed 3.7 mm/s | 3.7 mm/s
  - Minimum feed speed 0.10 mm/s | 0.065mm/s
  - Maximum feed speed of Z axis 9 mm/s | 9 mm/s
  - Minimum feed speed of Z axis 0.38 mm/s | 0.25 mm/s
- Maximum feed distance:
  - Y axis 210mm
  - X axis 90mm
  - Z axis 300 mm

## LASER OPTICS COMPONENTS

- 10x binocular (Leica)
- Weld spot diameter regulator
- Directional mirror
- Focusing lens
- Protective glass
- LCD protective shutter

## DIMENSIONS AND WEIGHT

- Dimensions: width 472mm x height 1270mm x length 1160mm
- Weight: 190 kg net



#### CONTROL PANEL

Clear 10" screen interface designed for user-friendly operation.

#### LEICA BINOCULARS

High-quality binoculars with 10x or 16x magnification for precise welding position determination with accuracy up to 0,01mm.

#### JOYSTICK

Digital-analog joystick for smooth movement control in three axes + rotary motion, includes Teach-In function, synchronization relative to feed (0.05 - 3 mm) and intuitive welding path programming.

#### MOTORIZED TABLE

Allows positioning of the workpiece in three axes with adjustable speed.

#### WORKING LENS WITH PROTECTIVE GLASS

Designed to protect delicate optics from welding splatter and mechanical damage.

#### DOUBLE FOOT SWITCHES

Enables two welding modes (single or continuous) with automatic shielding gas supply function.

### ECO TECHNOLOGY & EQUIPMENT

- Tiltable and sliding laser resonator
- Nd: YAG crystal laser source
- Interface with control and system monitoring function
- Control panel for adjusting machine operation parameters, including power, pulse time, and frequency
- Efficient, internal water-air cooling system with optional external cooling system connection
- Shielding gas supply controlled by a magnetic solenoid valve

TECHNICAL PARAMETERS	ECO ONE	ECO 160	ECO 200
Laser type	Nd: YAG	Nd: YAG	Nd: YAG
Max. mean power	110W	160W	200W
Pulse peak power	6 kW	9 kW	11 kW
Max. pulse energy	70 J	100 J	120 J
Pulse duration	0,2 - 20 ms		
Pulse frequency	0,5 - 20 Hz		
Focus diameter	0,03 - 2,0 mm		
Line voltage (V/Ph/Hz)	240 V / 1 Phase	380 - 420 V AC / 3 Phase	
<b>No.</b>	<b>ECO-LPONE</b>	<b>ECO-LP160</b>	<b>ECO-LP200</b>

## Laser safety curtain

Mobile modular protective curtain used for collective protection during laser welding with a class 4 laser. Made from durable material, complying with the EN 12254 standard. Dimensions of a single module: 1.3 m (width) x 1.9 m. Modules can be connected using a set of additional connectors – there are no limits on the number of modules. All wheels are equipped with locks. Weight: 22 kg

**Order no.** 19-1.000

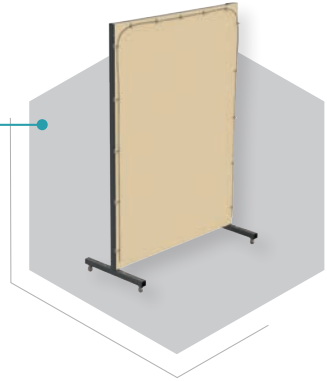

## LED lighting on a flexible arm

The lamp provides ideal, spot lighting for the welded part. The magnetic base allows the lamp to be positioned anywhere according to needs, whether working with a laser or on CNC machines and machining stations. Standardly equipped with an LED module with a light color of 5700 K.

Type	Order no.
IR filter for LED lamp (2 mm) complete with O-rings	2-1.023
LED module, cold white 5700 K	2-1.024
LED module, cold white 5700 K	2-1.270
LED module, warm white 3000 K	2-1.271

## Binocular

High-quality Leica binoculars for all Laserpoint machines, providing ergonomic 45° tilt.

Type	Order no.
Binocular Leica Inclined 45°	17-3.100
Okular 10 x 23 mm (1 piece), adjustable	17-3.101
Crosshair graticule	17-3.102
Rubber eyecups for Okulars (1 pair)	17-3.103

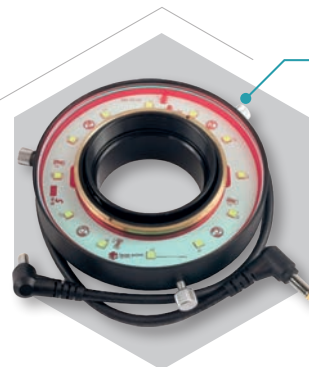

## LED ring light

The lamp provides uniform illumination of the entire welding area, reaching all corners thanks to its design. Made of anodized aluminum, significantly enhancing its durability and improving heat dissipation.

**Order no.** 2-1.030



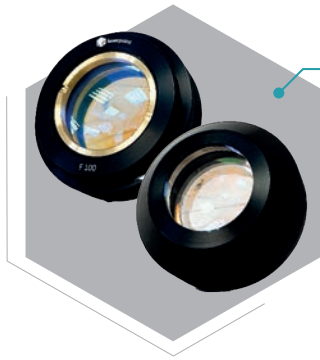

### Focusing lenses

Laser focusing lenses with housing and protective glass. They allow for focusing the laser beam at different distances from the lens.

Type	Order no.
F100 mm	17-3.301
F160 mm	17-3.302
F200 mm	17-3.303
17-3.304	17-3.304

### ErgoWedge 5° - 25°

Supplementary element for Leica binoculars, allowing for additional tilting. Significantly increases the ergonomics and comfort of the operator's work.

Type	Order no.
ErgoWedge®5°-25°	2-1.253

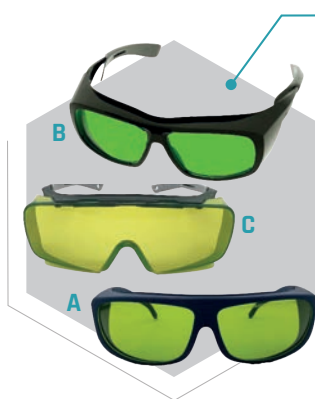

### Protective glasses

Lightweight glasses made of plastic, an essential element for eye protection when working with lasers.

Beam length: Fiber / YAG Laser (850-1300nm)

Protection level - OD4/OD9

OD4 - recommended for laser engravers

OD9 - recommended for high power welding lasers

Glasses version A and B - standard

Glasses version C - for those who wear prescription glasses.

Type	Order no.
Protective glasses type A - OD4	32-LSG-A
Protective glasses type B - OD9	32-LSG-B
Protective glasses type C - OD4	32-LSG-C

### Automatic voltage regulator 15000 VA

Three-phase mains voltage stabilizer combines. It combines the features of 2 devices: a voltage regulator and a surge protector. The main function is the automatic regulation of the voltage supplied at the input of the stabilizer.

Order no.	2-1.2526
-----------	----------



# Accessories

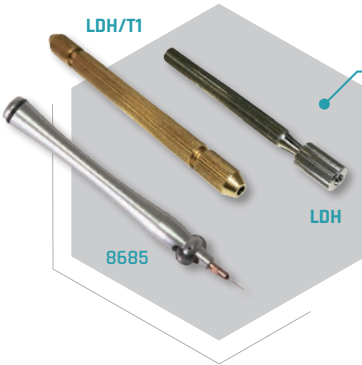

## Holder for fine wires

The welding wire holder facilitates the operator's work while providing hand protection from direct exposure to the laser heat and shielding the wires from external factors such as sweat or oils present on the hands. Available in three options.

Type	Order no.
Wireholder $\varnothing$ 0,2-1,0mm	32-LDH
Wireholder two-sided $\varnothing$ 0.2-0,6 mm	32-LDH/T1
Wireholder solid with rollers $\varnothing$ 0.1-0,5 mm	32-8685

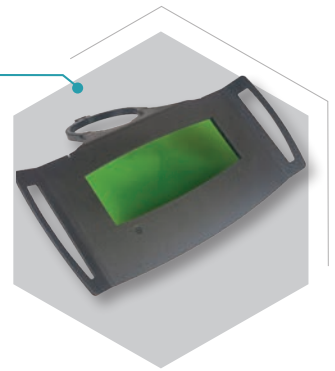

## Laser safety shield

A cover plate to further protect against laser reflections and heat, installed directly under binocular.

Order no. 2-1.255



## Focusing lens extension

Extends the focusing position, extension height 100mm.

Order no. 2-1.026

## Protective gas reducer (Argon)

Essential for gas-shielded welding, allowing optimal adjustment of the required amount of argon. Adjustable flow range of 0-5 l/min. Equipped with a quick-connect fitting for the regulator-laser hose.

Order no. 2-1.259





### Safety set interlock

To protect bystanders from laser radiation. The beacon signaling the laser work, together with the door contact switch that turns off the laser when the room doors are opened, is connected to the Interlook socket on the laser. Additionally set includes warning signboards.

Order no. **2-1.250**



### 360° rotational optical head

Thanks to its use, welding can be performed in hard-to-reach places, with large molds and cumbersome components. Adjustment range of 2 x 360° - horizontally and vertically.

Order no. **2-1.032**

### Magnetic balls

Magnetic balls of various sizes, designed for easy mounting and manipulation of the detail under the microscope. Their great advantage is exceptionally strong magnets.

Type	Order no.
Ø magn. 100mm, Ø sphere 120mm	<b>6-MCB100</b>
Ø magn. 125mm, Ø sphere 170mm	<b>6-MCB125</b>
Ø magn. 160mm, Ø sphere 210mm	<b>6-MCB160</b>



### CCD camera

Dedicated to observing and documenting the welding process on the material's surface. Analog camera, PAL format, observation field depends on the working lens.

Order no. **2-1.050**

# Accessories



## Service kit

Optimal set of parts dedicated for inspection, repair, and cleaning of the laser system. Laser lamp, LED lamp plug-in module cold white color 5700K, protective glass with IR filter for LedSpot lamp with gasket (28x2), lens protective glass Ø38x3, F20 water filter, spiral brush with handle, 25ml methanol bottle, pipette, plastic tweezers, telescopic mirror, air cleaning bulb, dry cleaning wipes, lint-free cleaning sticks.

Type	Order no.
Wearing part set S-120/60	2-1.256
Wearing part set S-200	2-1.257
Wearing part set S-300	2-1.258

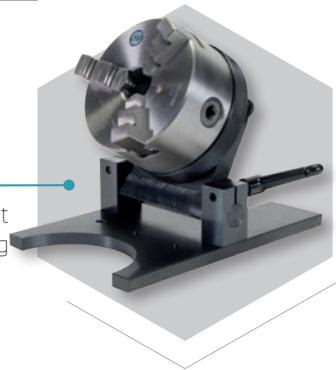

## Turning and swiveling holder, manual

The device is universal, extremely helpful in laser welding, and not only. Precise, axial clamping of the workpiece, the possibility of tilting it. Three-jaw chuck Ø 125 mm.

Order no. 6-DSV1



## Rotary-tilting holder, motorized

Universal, motorized rotary tool, facilitating precise, axial mounting of the workpiece with tilting capability. Three-jaw chuck Ø 125 mm DIN6350. Ability to reverse jaws for increased clamping diameter Full tilt adjustment of the chuck in the range of 0-90° Chuck lock at 0° angle. Dimensions: height 230 mm x width 212 mm x length 242 mm.

Description	Order no.
Ø 120mm	2-1.272

## PiggyClamp

Clever ball with a clamping system, two cranks work in opposite directions, so they can be quickly tightened or loosened. A very useful device for welding non-magnetic details.

Order no. 6-PC1

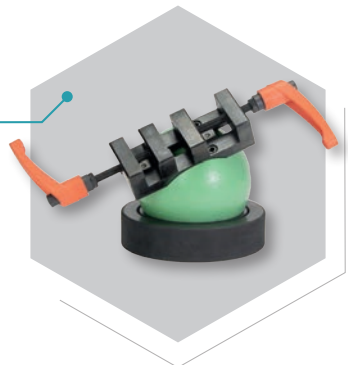

### Precision vice

Made from high-quality hardened steel, 58-62 HRC. Parallelism accuracy: +/- 5 microns. Available in three sizes. Optimal when combined with a magnetic ball.

length	W x H	Jaw height	max. opening	kg	Order no.
155 mm	50 x 50 mm	25	65	2,8	<a href="#">37-PSS01</a>
220 mm	80 x 80 mm	40	100	7,0	<a href="#">37-PSS02</a>
57 mm	33 x 27 mm	15	20	0,25	<a href="#">37-PSS03</a>

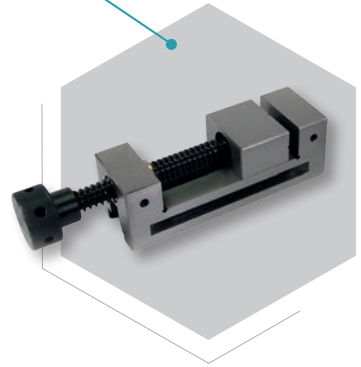

### Extractor III 200W

Mobile extraction-filtering system designed to absorb harmful combustion fumes, e.g., from laser welding and engraving of metals.

Description	Order no.
Extractor III 200W Mobile extraction and filtering system (without a suction hose)	<a href="#">36-780</a>
Extractor III - mobile extraction system Extractor III 200W (complete with Ø50mm x 2m extraction hose and Ø 50mm x 300 mm segment nozzle on a magnetic base (for open lasers), and 4x pre-filter)	<a href="#">36-780/L1</a>
Extractor III - mobile extraction system Extractor III 200W (complete with Ø50mm x 1.5m flexible (segmented) extraction arm and 4x pre-filter)	<a href="#">36-780/G1</a>



### External cooling system

Strongly recommended for heavily used laser systems and necessary for 300W Yag machines.

Description	Order no.
CY-6000 - Compressor cooling system with a cooling capacity of 3 kW, weight 60 kg, height 920 x width 480 x depth 550 + 120 mm (fittings and hoses), power supply 230 V AC (Single Phase), power: 1135 W. Ideal for 100-200W systems.	<a href="#">36-780/L1</a>
CY-8500 - Compressor cooling system with a cooling capacity of 8.2 kW, weight 120 kg, height 1110 x width 610 x depth 750 + 120 mm (fittings and hoses), power supply 400 V AC (Three Phase), power: 3570 W. Ideal for 200-300W systems	<a href="#">32-Ch285</a>

# Laserpoint around the world...

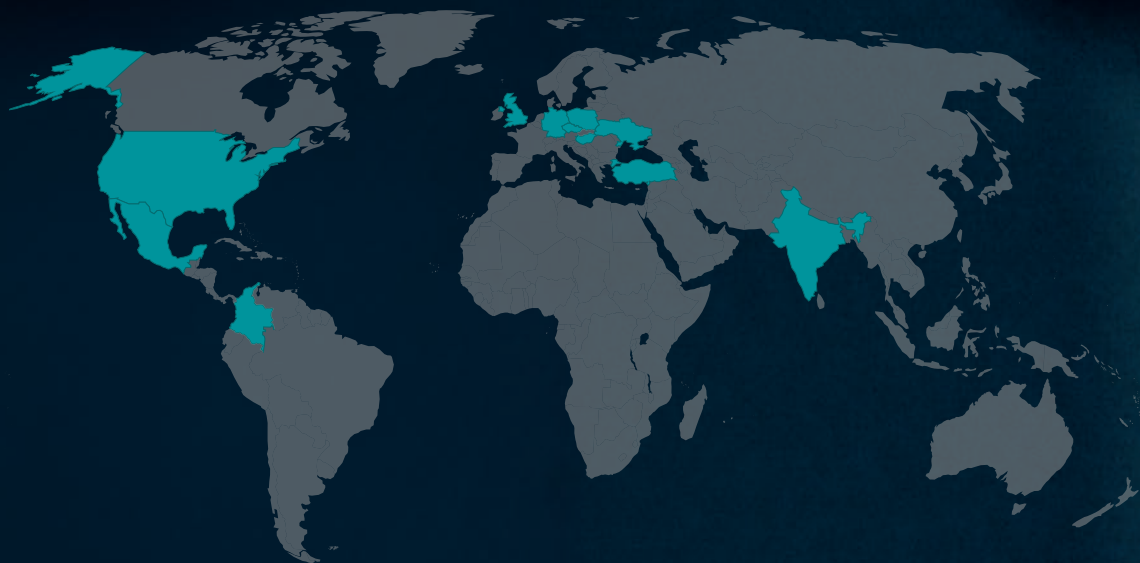

## HEADQUARTERS

### POLAND

**Laserpoint Sp. z o.o.**

22 Graniczna St., 52-002 Złotniki, Poland

Tel: +48 577 232 628

e-mail: [info@laserpoint.pl](mailto:info@laserpoint.pl)

[www.laserpoint.pl](http://www.laserpoint.pl)

## OUR PARTNERS

### EUROPE

Czech Republic · Ukraine

Germany · Hungary

United Kingdom

### NORTH AMERICA

United States · Mexico

### ASIA

India · Turkey

## REPRESENTATIVE:

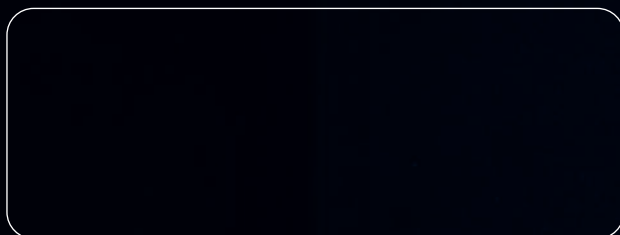

WELD BEYOND LIMITS

[www.laserpoint.pl](http://www.laserpoint.pl)